

Adaptive Neuro-Fuzzy Based Transient Stability Improvement Using UPFC

M.Senthil Kumar¹, Dr.P. Renuga², and K.Saravanan³

¹ Sona College of Technology/EEE, Salem, India

Email: senthileed@yahoo.com

² Thiagarajar College of Engineering/EEE, Madurai, India

Email: preee@tce.edu

³ Sona College of Technology/EEE, Salem, India

Email: saravanan070@rediffmail.com

Abstract— In this paper, the transient stability improvement using Unified Power Flow Controller (UPFC) has been designed with the application of the intelligent techniques such as combination of neural network and fuzzy logic. The Mamdani type fuzzy controller with constant center for output classes may not perform satisfactorily in all operating conditions. To overcome this limitation, it is made variable according to operating condition via a neural network. The Fuzzy logic controller uses four simple rules and two inputs (error and summation of error) which are derived from active power deviation at the bus following the UPFC. On the other hand, the inputs to the radial basis function neural network are taken as predisturbance real and reactive power at the generator bus whereas its output is the center of output classes of the fuzzy scheme. The performance of the new adaptive neuro-fuzzy controller is evaluated in a single-machine infinite-bus power system subjected to various transient disturbances which exhibits best damping performance in comparison to the Proportional and Integral (PI) as well as the Mamdani type fuzzy controller.

Index Terms— Transient Stability, Unified Power Flow Controller, Neuro-fuzzy, Radial basis function, Mamdani fuzzy

I. INTRODUCTION

With increased power transfer, transient and dynamic stability is of increasing importance for secure operation of power systems. Flexible AC Transmission Systems (FACTS) devices with a suitable control strategy have the potential to significantly improve the transient stability margin [1]-[5]. This allows increased utilization of existing network closer to its thermal loading capacity, and thus avoiding the need to construct new transmission lines. Amongst the available FACTS devices, the UPFC is the most versatile one that can be used to enhance system stability. The UPFC is capable of both supplying and absorbing real and reactive power and consists of two ac/dc converters. One of the two

converters is connected in series with the transmission line through a series transformer and the other in parallel with the line through a shunt transformer. The dc side of the two converters is connected through a common capacitor, which provides dc voltage for the converter operation. The power balance between the series and shunt converters is a prerequisite to maintain a constant voltage across the dc capacitor. As the series branch of the UPFC injects a voltage of variable magnitude and phase angle it can exchange real power with the transmission line and thus improves the power flow capability of the line as well as its transient stability limit. The shunt converter exchanges a current of controllable magnitude and power factor angle with the power system. It is normally controlled to balance the real power absorbed from or injected into the power system by the series converter plus the losses by regulating the dc bus voltage at a desired value.

Various control strategies to control the series voltage magnitude, angle and the shunt current magnitude have been presented [6]-[10]. The series converter voltage phasor can be decomposed into in-phase and quadrature components with respect to the transmission line current. The in-phase and the quadrature-voltage components are more readily related to the reactive and real power flows in the transmission system. During short-circuit and transient conditions, the decrease in real power can be arrested by controlling the quadrature component of the series converter voltage and hence the improvement in transient stability. The Proportional and Integral (PI) controller used for the purpose have inadequacy of providing robust control and transient stability over a wide range of power system operating conditions. The efficiency of fuzzy controller compared to PI controller has already been established in the literature. Further, it has been proved that it is a variable gain PI

controller whose gain varies according to the operating condition. The mamdani type fuzzy controller used to provide a constant center value in any class for its consequent decision. But, as the complexity of the control system increases it requires the variation in its center value. On the other hand the neural network has the capability of pattern recognition and nonlinear mapping of input and output. Hence, in this paper a combination of fuzzy and neural network is attempted to make a variable center Mamdani type fuzzy controller. The optimal value of centers for the output classes of the fuzzy controller at different operating conditions is obtained through Integral Absolute Error Criteria (IAEC) with rotor angle deviation as error. With these centers as output and the pre-disturbance conditions as input a neural network can be trained, which will specify the proper centers for the fuzzy controller at any condition after completion of proper training. Therefore, combining both the fuzzy and neural network will result an intelligent optimal Mamdani type fuzzy controller.

The Mamdani type fuzzy controller presented in this paper uses error (er) and integral of error ($\sum er$) as inputs and quadrature component of series injected voltage to the line current as output. The choice of quadrature component generation from real error is based upon the fact that when the series injected voltage by UPFC is at right angle to line current it directly affects the reactance of the line hence regulates the real power flow. Further, the integral of error being an input to the controller helps to design the rule base more effectively from the physical behavior of the power system following a transient disturbance such as fault. On the other hand a Radial Basis Function Neural Network (RBFNN) can approximate nonlinear function to any extent is utilized for the functional approximation. The neural network is trained with output as the optimal center of the fuzzy controller and real and reactive power at any operating condition as inputs. The fuzzy controller uses the optimal center generated from the RBFNN at any given condition to produce an Adaptive Neuro-Fuzzy (ANF) controller. This adaptive neuro-fuzzy UPFC provide excellent damping and dynamic performance improvement in case of power systems subjected to a variety of transient disturbances.

II. UNIFIED POWER FLOW CONTROLLER (UPFC)

The general structure of the UPFC contains two "back to back" voltage source converters using insulated gate bipolar transistor (IGBT) or Integrated Gate Commutated Thyristor (IGCT) with a common DC link. First converter is connected as parallel and another converter as series with transmission line. The shunt converter is used to provide active power demanded by the series converter through a common DC link. The series converter provides the main

function of the UPFC by injecting an AC voltage with controllable magnitude and phase angle. The transmission line current flows through series converter and therefore, it exchanges the active and reactive power with the AC system. Since the converters are connected to a common DC link, they exchange only active power and there is no reactive power flow between them. It means that reactive power could be controlled independently at both converters. Generally, this structure (Fig.1) enables voltage control by the shunt inverter and independent active and reactive power flow control by the series inverter.

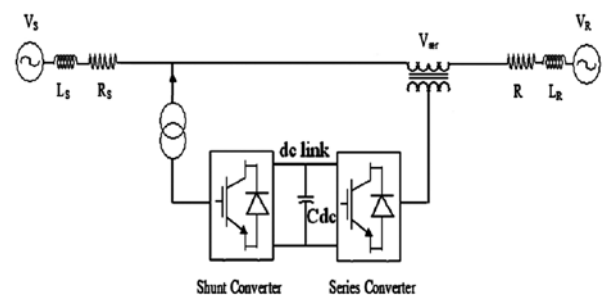

Fig.1: Schematic of UPFC

In the parallel branch of UPFC the active power is controlled by the phase angle of the converter output voltage. In the series branch of UPFC the active and reactive power flows in the transmission line are influenced by the amplitude as well as the phase angle of the series injected voltage. Therefore, the active power controller can significantly affect the reactive power flow and vice versa. In order to improve the interaction between the active and reactive power control, a so called decoupled Watt-Var control algorithm based on d-q axis theory was used [10]-[11]. The UPFC model consists of a controllable voltage source connected in series with the transmission line and two current sources added in shunt [12]-[13]. The presented model consists of two ideal synchronous voltage sources connected in series and shunt with transmission line.

III. NEURO-FUZZY SCHEME FOR UPFC

A control strategy based upon RBFNN and Mamdani type fuzzy controller is presented in this section. The limitation of constant output center Mamdani type fuzzy controller is eliminated by augmenting it with a RBF neural network to produce the neuro-fuzzy controller.

A. Fuzzy Controller

As shown in the literature, regardless of the type, fuzzy controllers are just conventional non-linear controllers and can produce satisfactory results when constructed properly. These are mainly divided into

two categories: the position type and the velocity type [16]. The former known as PDFLC generates the

later known as PIFLC generates incremental control input (Δu). But this concept of generating control signal from error and its derivative presents a difficult task in the part of the design to formulate the rule base of the fuzzy controller for UPFC to improve transient stability. In the power system to enhance the transient stability performance almost care should be given for proper control signal generation during the fault and immediately after the clearing of the fault. During fault as real power flow becomes zero the error ($P_{ref} - P_{actual}$) in the bus immediately becomes positive whereas just after the fault is cleared it becomes negative. From the physical behaviour of the power system it is found that the UPFC quadrature voltage component should be negative during and immediately after the clearing of fault to impose a capacitive effect over the transmission line. To take care of this requirement one of the input to the fuzzy controller is taken as integration of error as it will not change its sign, from during the fault to immediately after clearing of fault. The integration of error is substituted with sum of error for simplification in digital simulation. The fuzzy logic controller (FLC) is realised through three sections: fuzzification, inference engine and defuzzification. The inputs are fuzzified into three classes through the membership function given in Figure 2. The center of the positive and negative classes for which the membership value 'one' is decided by hit and trial approach for error and summation of error, respectively. These fuzzified inputs are given to the inference engine containing the expert rules. The expert rules that are decided based upon the physical behaviour of the power system are represented in Table 1. Where N, P, Z represents Negative, Positive and Zero, respectively. Every entity in the table represents a rule. The antecedent of each rule conjoins the error and summation of error fuzzy set values.

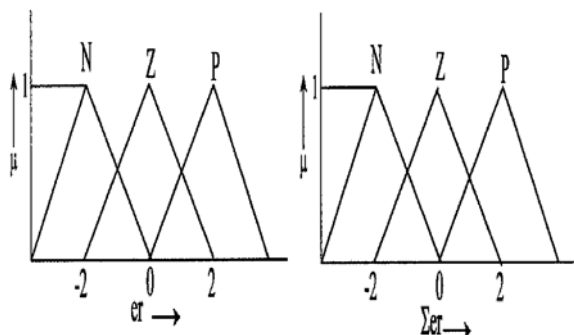

Fig. 2 Membership function for inputs

Table 1 Expert rules for FLC

	er	N	Z	P
Σer	N	Z	N	N
	Z	Z	Z	N
	P	P	P	N

control input (u) from error and error rate whereas the

B. Adaptive Neuro-Fuzzy Inference System Architecture

The architecture of the Adaptive Neuro-fuzzy Inference System (ANFIS) is shown in Fig.3. Consider a first-order sugeno fuzzy model with two input x and y and one output with above-mentioned fuzzy IF-THEN

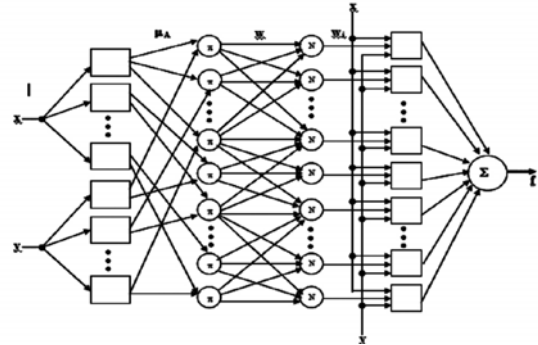

rules.

Fig.3. Architecture of Adaptive Neuro-Fuzzy Inference System

IV RESULTS AND DISCUSSIONS

For simulation of the proposed method Fuzzy Logic Toolbox in the MATLAB is used. The test system consists of two fully symmetrical areas linked together by two 230 kV lines of 220 km length. Each area is equipped with two identical round rotor generators rated 20kV/100 MVA. Fig.4-9 show the transient response of the system with conventional PI and adaptive neuro-fuzzy UPFC. From the results it can be seen in comparison to conventional PI controller, the significant damping is achieved using the new adaptive neuro-fuzzy controller. A hybrid neuro-fuzzy controller is designed using the procedure presented above. The proposed scheme utilizes sugeno-type fuzzy inference system controller, with the parameters inside the fuzzy inference system decided by the neural-network back propagation method. The ANFIS is designed by taking Area control Error (ACE) and rate of change of ACE as inputs. This network consists of five layers with, each layer representing a specific part in ANFIS controller. Fig.4-9 show system transient response of a two area power system of controller with 1% step load perturbation in area-1 and 2. In all Figures the performance of the proposed adaptive neuro-fuzzy controller is compared with a conventional PI controller. It is clear from figures that the designed adaptive neuro-fuzzy controller is robust in its operation and gives best damping performance for

both frequency and tie line power. Simple architecture of the controller has the potential of implementation in

real time environment.

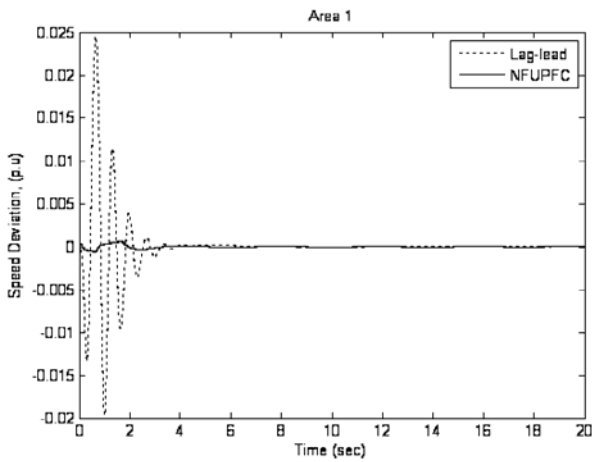

Fig.4 Speed Deviation Vs Time

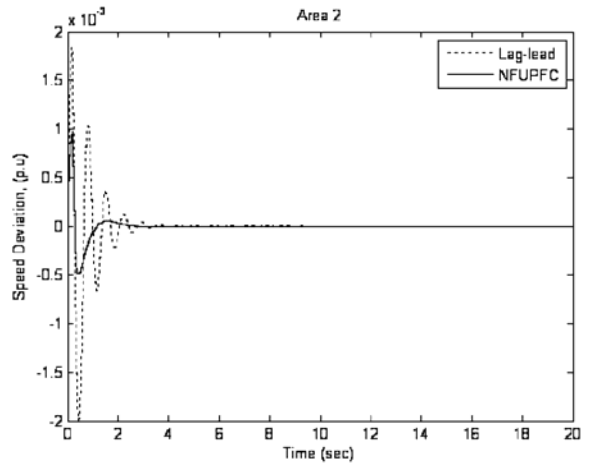

Fig. 7 Speed Deviation Vs Time

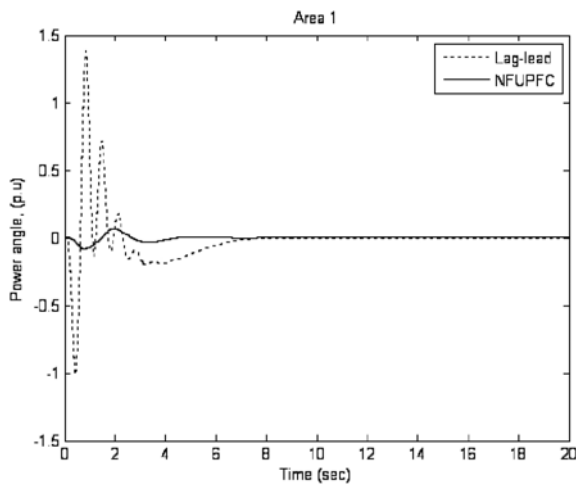

Fig.5 Power Angle Vs Time

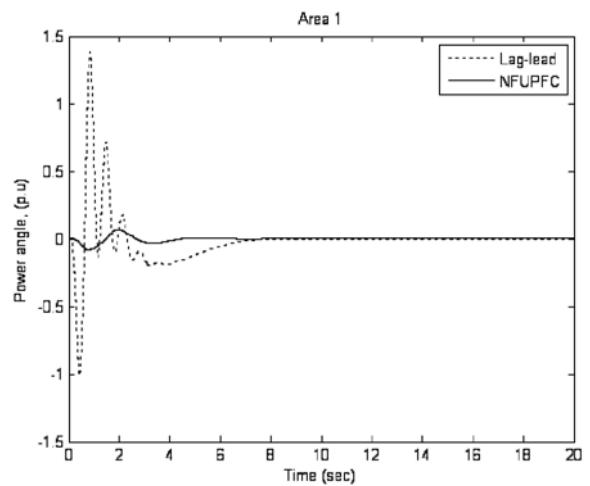

Fig.8 Power Angle Vs Time

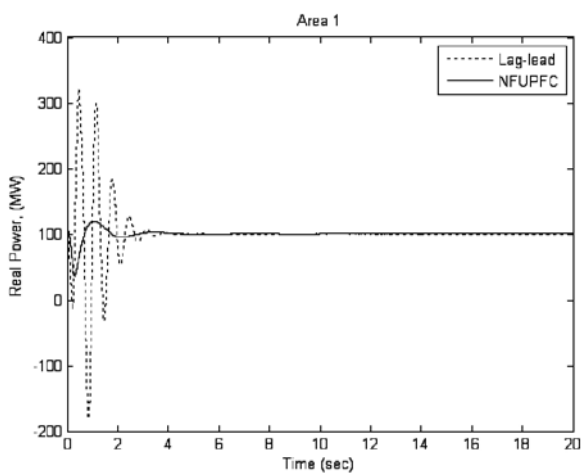

Fig.6 Real Power Vs Time

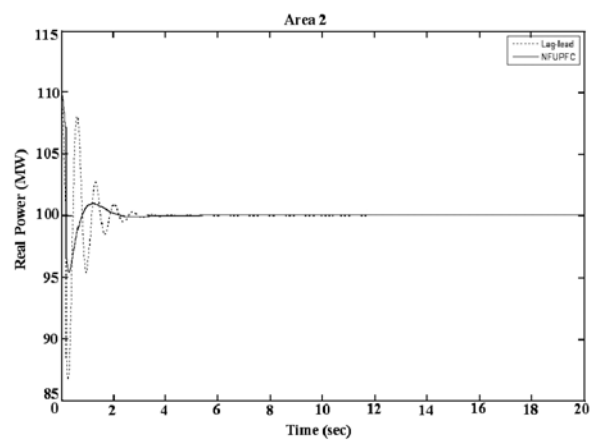

Fig. 9 Real Power Vs Time

V CONCLUSION

This paper presents an adaptive neuro-fuzzy based UPFC to improve the transient stability performance of a single machine-infinite-bus power system. The expert rule base of the fuzzy controller with only nine rules is systematically designed based upon the physical behaviour of the power system following a fault. The fuzzy controller uses the real power deviations and its integration at the UPFC injection bus as input to provide the magnitude of the quadrature component of the variable voltage source for the series converter. The centers of the fuzzy scheme are generated from a trained RBFNN based upon the pre-disturbance operating conditions of the power system. The segregation of RBFNN and fuzzy scheme presented in this paper will present an adaptable fuzzy controller. Both the parameters of the PI controller and optimal centers of the FLC at a particular operating condition are decided with ITAE criteria. The simulation results prove that the designed adaptive neuro-fuzzy is robust in its operation and gives best damping performance compared to its conventional counterpart as well as the simple Mamdani type fuzzy controller.

REFERENCES

- [1]. Prechanon Kumkratug "Application of UPFC to Increase Transient Stability of Inter-Area Power System", Journal of Computers, vol 4, no 4, April 2009, p 283-287.
- [2]. N.Karpagam, D. Devaraj "Fuzzy Logic Control of Static VAR Compensator for Power System Damping" International Journal of Electrical Power and Energy Systems Engineering, February 2009.
- [3]. Prechanon Kumkratug, Panthep Laohachai, "Direct Method of Transient Stability Assessment of Power System with a SSSC", Journal of Computers, vol 2, no 8, October 2007.
- [4]. S.V.Ravi Kumar, S.Siva Nagaraju, "Transient Stability Improvement using UPFC and SVC", ARPJ Journal of Engineering and Applied Sciences, vol 2, no 3, June 2007.
- [5]. S.V.Ravi Kumar, S.Siva Nagaraju, "Functionality of UPFC in Stability Improvement", International Journal of Electrical and Power Engineering, vol 1, no 3, p 339- 348, 2007.
- [6]. Alberto D. Delrosso, Claudio A. Canizares and Victor M. Dona. "A study of TCSC controller Design for Power System Stability Improvement" *IEEE Transactions on Power Systems*, Feb, 2003, pp 1-10.
- [7]. S.Panda, Ramnarayan N. Patel. "Improving Power System Transient Stability with an off-Centre Location of Shunt Facts Devices" *Journal of Electrical Engg*, vol 57, no 6, 2006, pp 365-368.
- [8]. L Gyugyi, C D Schauder, S L Torgerson and A Edris. "The Unified Power Flow Controller: A New Approach to Power Transmission Control." *IEEE Transactions on Power Delivery*, vol 10, no 2, 1995, p 1088.
- [9]. P K Dash, S Mishra and G Panda. "Damping Multimodal Power System Oscillation using a Hybrid Fuzzy Controller for Series Connected Facts Devices" *IEEE Transactions on Power Systems*, vol 15, no 4, November, 2000, p 1360.
- [10]. S.Round, Q. Yu, et al, "Performance of a Unified Power Flow Controller Using a d-q Control System," *AC and DC Transmission Conference*, April 1996.
- [11]. D. G. Cho, E. Ho. Song, "A Simple UPFC Control Algorithm and Simulation on Stationary Reference Frame," *ISIE Conference*, Pusan, Korea, pp.1810-1815, 2001.
- [12]. K. K Sen, E. J. Stacey, "UPFC- Unified Power Flow Controller: Theory, Modeling and Application" *IEEE Trans. on Power Delivery*, Vol. 13, No. 4, pp. 1453-1460, October 1998.
- [13]. E. Lerch, D. Povh, R. Witzmann, R. Hlebcar and R. Mihalic, "Simulation and Performance Analysis of UPFC," *CIGRE*, August 1994.
- [14]. J. Bian, T. A. Lemak, R. J. Nelson and D. G. Ramey, "Power Flow Controller Models for Power System Simulations," *Power System Technology*, Vol. 19, No. 9, pp. 15-19, September 1995.
- [15]. Z. Huang, Y. Ni, C. M. Shen, F. F. Wu, S. Chen and B. Zang, "Application of Unified Power Flow Controller in Interconnected Power System- Modeling, Interface, Control Strategy and Case Study," *IEEE Trans. Power Systems*, Vol. 15, No. 2, pp. 817-824., May 2000.
- [16]. S Mishra, A K Pradhan and P K Hota. "Development and Implementation of a Fuzzy Logic based Constant Speed DC Drive" *Journal of The Institution of Engineers (India)*, pt EL, vol 79, Dec 1998, p 146.