

A New Method to Control Dynamic Stability of Power System through Wave Variables and Signal Prediction via Internet

Soheil Ganjefar*
Member of IEEE
Bu-Ali Sina University
Hamedan, Iran
S_ganjefar@basu.ac.ir

M. Rezaei
Electrical Department
Bu-Ali Sina University
Hamedan, Iran
Mr_rezayi84@yahoo.com

Abstract— the purpose of this article is to improve dynamic stability of power network by using a new method. In this method the entire stability of the network creates from one point and all the stabilizers of power network collect in a PSS bank. The connecting channel between network generators and PSS bank is internet. Expansion and vastness of internet make it easily accessible every where. In the next part, two limitations of internet for the network will be discussed. Then, using two methods of wave variables and signal prediction, these limitations will be improved. The results of simulation prove effectiveness of these methods.

Keywords- dynamic stability of power system; wave variables method; signals prediction.

I. INTRODUCTION

Stability of a power system includes 4 major parts, permanent stability, transient stability, voltage, and dynamic stability (small signal) [1]. In this article, dynamic stability will be studied. Significant study of power systems stability were began in 1920 [2], and the first small scale test were done in 1924 [3]. In 1925, the first stability tests of a real system were done [4,5]. The complete outage in November of 1965 in north east of USA, affirmed the significance of power system stability [1]. One of the most important parts of power system stability is dynamic stability. Controlling devices to improve dynamic stability of power systems are called power system stabilizers (PSS). The problem is to determine the proper place of stabilizers next to generators which needs those stabilizers [6]. Changes and expansions of the network may cause movement of stabilizers. One solution of this problem is collecting the stabilizers in one place of network and connecting them to network through a channel. In this article, we use internet as a vast and easy-accessible network instead of connecting channel which we try to settle the limitations by using two new methods. Available simulations in this article

have been done by MATLAB software as a standard medium [7].

II. POWER SYSTEM STABILIZER

In researches of this article, after linearization of system around operating point, single machine system before infinite bus is used. To analyze dynamic stability of local modes which include most of the problems of dynamic stability, we can use infinite shin model. Figure 1 shows the block structure of this system. The block model was appeared first in [8] and then in [9]. K factors can be calculated from available calculations in power systems, regarding machine values and operating point of the network. Stabilizers, through sampling from signal variations of angular speed and after their modulation, will send a controlling signal to generator exciter. Electric torque includes two parts: damping and synchrony. Synchrony part which is a coefficient of $\Delta\delta$, will improve transient stability and damping part which includes $\Delta\omega_r$, will improve dynamic stability [10]. If PSS is designed in a form that supply lag of diagram block path from Δv_s and $\Delta\omega_r$ (this phase is because of blocks of path delay like exciter system), will generate a net coefficient from $\Delta\omega_r$ in electric torque (ΔT). According to previous part, a normal PSS includes three major parts: phase compensator uni or multi level, a high-pass transform function to remove PSS effect in a permanent form and non reaction against basic angular speed and a compensator coefficient (figure 2).

A generator system is considered with following values against infinite bus [1]:

$$\begin{aligned} K_1 &= 0.7643 & K_2 &= 0.8649 & K_3 &= 0.3230 \\ K_4 &= 1.4187 & K_5 &= -0.1463 & K_6 &= 0.4168 \\ T_3 &= 2.365 & T_R &= 0.02 & G_{ex}(S) &= 200 \end{aligned} \quad (1)$$

PSS for this generator has these values:

$$\begin{aligned} K_{STAB} &= 9.5 & T_w &= 1.4(\text{sec}) \\ T_1 &= 0.154(\text{sec}) & T_2 &= 0.033(\text{sec}) \end{aligned} \quad (2)$$

* Corresponding author. Bu-Ali Sina University, Hamedan, Iran

Figure 3 shows Pole-Zero map of system without PSS. Existence of two poles in the right side of the axis represents instability.

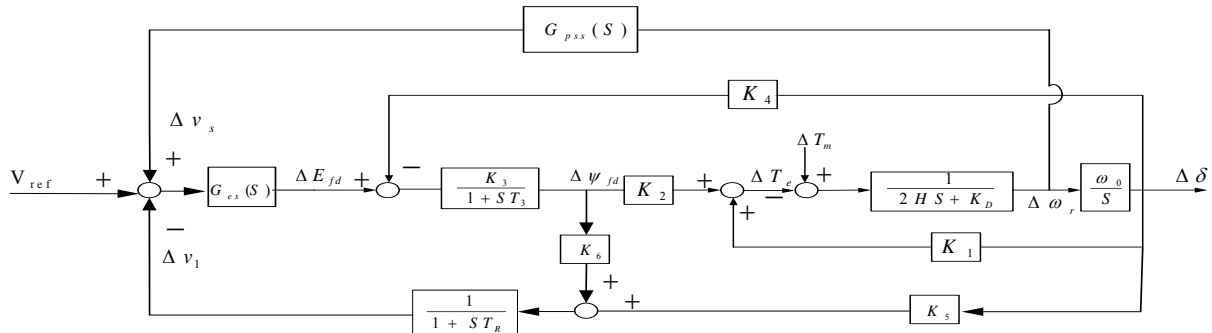

Fig. 1: Block diagram of system with exciter system, AVR, and PSS

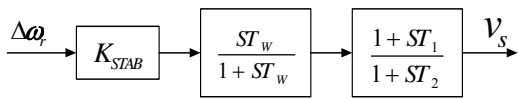

Fig. 2: Major parts of a normal PSS

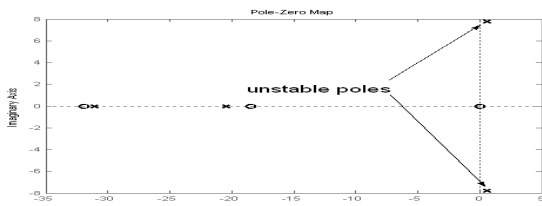

Fig. 3: Pole-Zero map of system without PSS

Figure 4 shows Pole-Zero map of system with PSS. Movement of two poles to the left side of the axis represents stability.

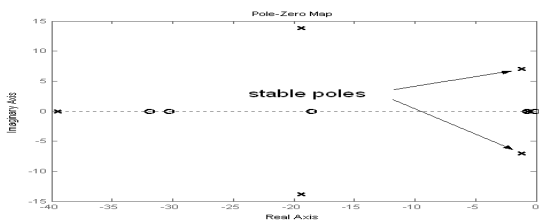

Fig. 4: Pole-Zero map of system with PSS

For studying the system in a dynamic condition, we apply a disturbance in mechanical torque in form of a pulse in third second with 0.1 second width. Figure 5 shows the reaction of the system to the disturbance with PSS and without PSS.

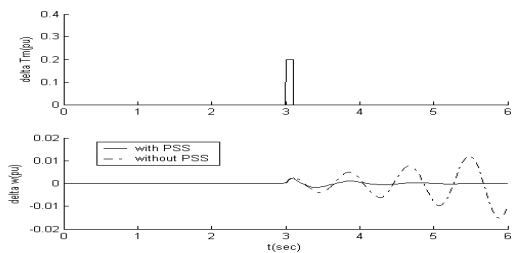

Fig. 5: Response of the system to the disturbance with PSS and without PSS

III. TELEOPERATION SYSTEMS

Teleoperation system is generalization of human senses with ability to perform works through mechanical arm in a far situation [11]. In these systems, by using mechanical arm in master system and applying a force, issue its order. By applying this force, mechanical arm will move with v speed which this speed will transfer to slave system, by a channel, which includes a mechanical arm. Accordingly, mechanical arm transfers the orders quickly, receive the answers and generate a force in work medium. This force will transfer to master system through connecting channel (figure 6).



Fig. 6: A conventional teleoperation system

If the distance between master system and slave system is low, we use mechanical connecting channel, otherwise, we use electrical connecting channel [12]. Some of the functions of teleoperation systems are robots with remote control, surgery from far distance and telelaboratories. Regarding expansion of internet and its significant abilities, and its epidemic, it is easily accessible every where.

IV. USING OF INTERNET IN NETWORK DYNAMIC STABILITY

We can use telecommunication and electrical channels to measure, control and stabilize power network, which a sample of it through satellite as a connecting channel was mentioned [13]. Therefore, using of teleoperation systems to control network systems can be useful. In this article, internet is used as a connecting channel between synchronous generator and dynamic power system stabilizer. Every generator in network is connected to PSS through internet channel. Error signal of each generator will send to PSS with a delay and after modulation of this signal, a controlling signal through internet will send to the generator exciter with a delay. The relationship between network generators and central bank PSS is shown in figure 7.

There are two important problems while using internet. According to TCP/IP protocol, there would be delay in internet to make dysfunctions in system. In this protocol, there is no disconnecting in internet [14]. In UDP protocol, there is a little delay but again there is disconnecting [15]. In the next part, two new methods will be introduced to remove these problems.

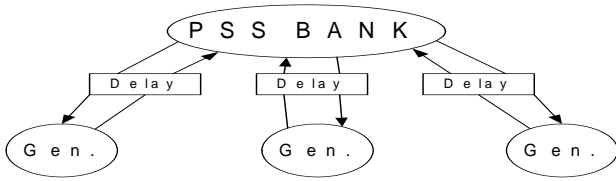

Fig. 7: Relationship of network generators and PSS bank

V. DELAY EFFECT ON SYSTEM

Delay makes some difficulties for stability of various systems. If delay will become 0.072 second, the previous system will become unstable. Figure 8 shows the response of the system to this disturbance with 0.072 second delay. Probably, the delay varies with time. In simulations for this article, we use random delay signal with normal distribution and sampling time of 0.1 second. With maximum delay range in variable signals, up to 0.1 second, system keeps its stability. With increasing of random delay range to 0.2 second, system becomes unstable (Figure 9).

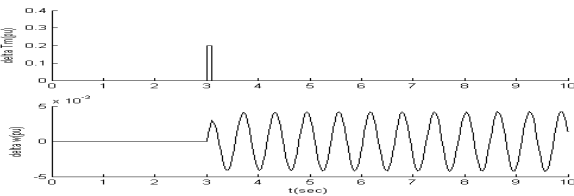

Fig. 8: system answer to a fixed delay

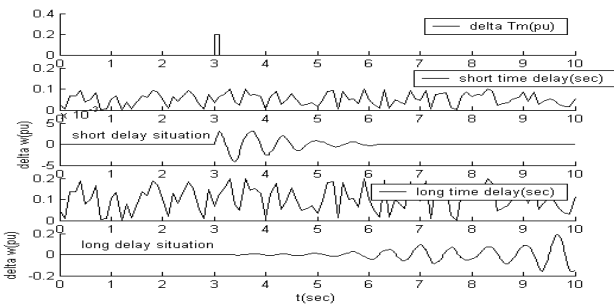

Fig. 9: System response to disturbance with variable random delay varies with time

VI. WAVE VARIABLES METHOD

One of the useful methods for delay reduction is wave variables method. In this method, by locating two variable transform functions on two sides of the signal path (between master and slave), delay is reduced. The location of two functions and its calculations is mentioned in [16] with full details.

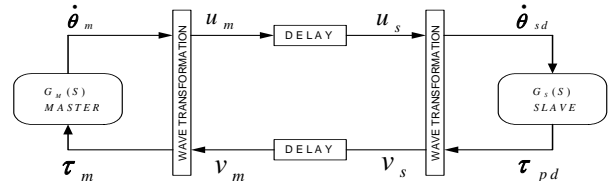

Fig. 10: Application of wave variable on system

The relationship between system inputs and outputs in figure 10 are [16]:

$$u_m(t) = \frac{b\dot{\theta}_m(t) + \tau_m(t)}{\sqrt{2b}} \quad u_s(t) = \frac{b\dot{\theta}_{sd}(t) + \tau_{pd}(t)}{\sqrt{2b}} \quad (3)$$

$$v_m(t) = \frac{b\dot{\theta}_m(t) - \tau_m(t)}{\sqrt{2b}} \quad v_s(t) = \frac{b\dot{\theta}_{sd}(t) - \tau_{pd}(t)}{\sqrt{2b}}$$

Parameter b (the only independent factor in above equations) is for adjusting wave variable method for the highest effectiveness.

Now, we place two wave variable transform functions in the system. Probably, because controller keeps the stability of machine, mistakenly, one may use it as master and use machine as slave. This mistake makes wrong results in simulations. In fact, because independent input of system (dynamic disturbance) enters the system, machine becomes master system and PSS becomes slave system. Value of parameter b will adjust as 22 (b=22). Figure 11 shows the system response to this disturbance, using wave variable. Although delay is four times greater than marginal stability (0.3 second), system keeps its stability.

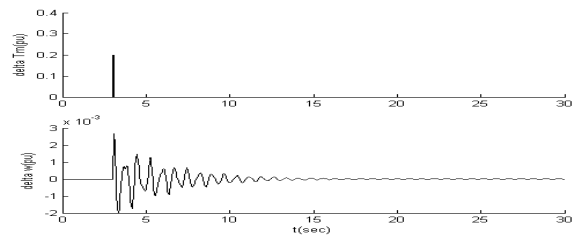

Fig.11: System response to wave variables with fixed delay

In this part, we apply random delay with maximum range of 1 second on system. Again, although the delay range is five times greater than the previous delay, system keeps its stability (figure 12). Therefore, the function of wave variables method in stabilizing systems with delay is recognized.

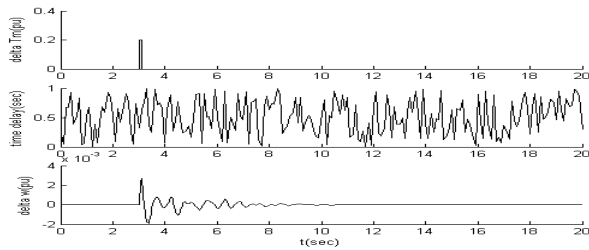

Fig.12: System response to wave variables with delay varies with time

VII. DISCONNECTING IN INTERNET

If there is a disconnecting in internet while stabilizing operation, PSS will exit from the circuit and system becomes unstable. In this condition, output frequencies increase and this action continues till reconnection to internet. In figure 13, after internet disconnection from 4 second to 10 second, responses range becomes three times greater than the first variation (before disconnecting). In this figure, when interrupt signal becomes zero, internet disconnects and when it becomes 1, internet reconnects.

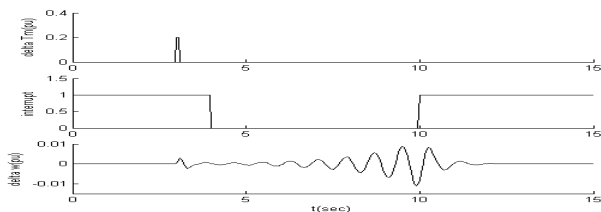

Fig.13: Effect of internet disconnection on system operation

VIII. LEAST SQUARE ESTIMATOR

A useful method for prediction the disconnected signal is least square estimator method. Using this method, in a case of disconnecting, we can anticipate controlling signal which is sent from PSS. This method is described in [17] in details and in this article its results are used.

The purpose of this method is to predict operation of a system using income and outcome information. Because of needs of this article, we use this method for single input and single output systems (SISO). The basic of least square estimator method is shown in following equation:

$$y = \theta_1 f_1(u_1) + \theta_2 f_2(u_2) + \dots + \theta_n f_n(u_n) \tag{4}$$

u is old information, f is function on the basis of u and θ is the coefficient of determination of system specification. The above equation is shown in the form of a matrix to estimate the outcome:

$$A\theta = y \tag{5}$$

Matrix A is the general function of previous inputs. Every step time defines a line from above matrix, (line k from matrix A is represented as a_k). According to the following two equations, having system information in step k, we can calculate system specification matrix in step k+1 and therefore having inputs in step k+1, we can guess outputs in k+1.

an even numbered affiliation (e.g., if there are five affiliations, place your cursor at end of fourth affiliation). Drag the cursor up to highlight all of the above author and affiliation lines. Go to Column icon and select “2 Columns”. If you have an odd number of affiliations, the final affiliation will be centered on the page; all previous will be in two columns.

$$P_{k+1} = P_k - \frac{P_k \cdot a_{k+1} \cdot a_{k+1}^T \cdot P_k}{1 + a_{k+1}^T \cdot P_k \cdot a_{k+1}} \tag{6}$$

$$\theta_{k+1} = \theta_k + P_{k+1} \cdot a_{k+1} (y_k - a_{k+1}^T \cdot \theta_k)$$

For algorithm, we need initial values of P_o and θ_o .

IX. OPERATION OF SIGNAL PREDICTOR IN SYSTEM

Here, we place a signal estimator near to the generator for estimation of control signal. Previous values of system here include variations signals and controlling signals of previous steps as well as current variations signals which we can guess current controlling signal by using them. For determination of matrix A values from variations and controlling signals, we must use previous steps in linear form.

Figure 14 shows system response which has wave estimator to disturbance in a case of disconnecting. Moreover, in this figure, outcome controlling signal of PSS and its anticipated form on the base of pre unit is shown. Through least square estimator method, we can avoid instability of system and enlargement of variations while internet disconnection.

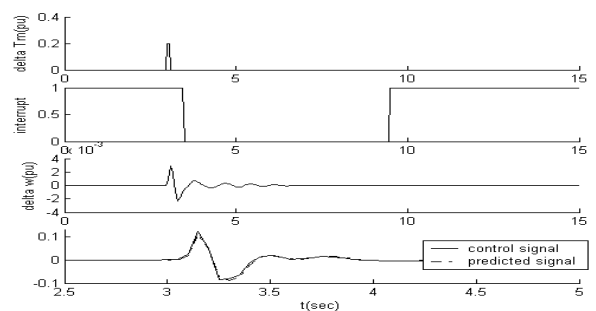

Fig. 14: System response to disturbance which has predictor for internet disconnection

X. CONCLUSION

In this article a new method to improve dynamic stability of power system was introduced. Some advantageous of this

method include: reduction of number of network stabilizers, controlling dynamic stability of the whole system in one point, increasing flexibility of network, as well as needlessness to movement of stabilizers for expansion of network. In the next part of the article, delay and disconnection in internet were introduced as two limitations of this method which using two new methods of wave variable and signal prediction, system operation will be improved against these two limitations. Results of simulation prove the efficiency of these methods.

REFERENCES

- [1] P.Kundur, *Power System Stability and Control*. NewYork: McGrawHill, 1994.
- [2] C.P. Steinmetz, "Power Control and Stability of Electric Generating Stations", *AIEE Trans.*, Vol. XXXIX, Part II. pp.1215, July-December, 1920.
- [3] R.D. Evans and R.C. Bergvall, "Experimental Analysis of Stability and Power Limitations", *AIEE Trans.*, pp. 39-58, 1924.
- [4] R. Wikins, "Practical Aspects of System Stability", *AIEE Trans.*, pp. 41-50, 1926.
- [5] R.D. Evans and C.F. Wagner, "Further Studies of Transmission System Stability", *AIEE Trans.*, pp. 51-80, 1926.
- [6] Q. Liu, Z. Yong, X. He and H. Li, "Study on the Selection of PSS Installing Location in Power Systems," *IEEE/PES Transmission and Distribution Conference & Exhibition: Asia Pacific Dalian, China*, 2005.
- [7] W. E. Dixon, D. M. Dawson, B. T. Cpsic, M. S. Queiroz, "Toward the Standardization of a MATLAB-based Control Systems Laboratory Experience for Undergraduate Students", in Proc. *American Control Conf.* Arlington, VA, pp. 1161-1166, 2001.
- [8] W.G Hefforn and R.A. Philips, "Effects of Modern Amplidyne Voltage Regulator in Underexcited Operation of Large Turbine Generators," *AIEE Trans.*, Vol. PAS-71, pp. 692-697, August 1952.
- [9] F.P. DeMello and C. Corcordia, "Concepts of Synchronous Machine Stability as Affected by Excitation Control," *IEEE Trans.*, Vol. PAS-88, pp. 316-329, April 1969.
- [10] Asler, M.J; Schaefer, R.C, "Understanding power system stability," *Protective Relay Engineers*, 2005 58th Annual Conference for 5-7 April 2005 Page(s):46-67.
- [11] T.B. Sheridan, "Telerobotics," *Automatica*, 25 (4): pp. 487-507, 1989.
- [12] Jean Vertut and Philippe Coiffet, *Teleoperation And Robotics, Evolution And Development* Anchor Press Ltd;
- [13] K. E. Holbert, G. I. Heydt, Ni. Hui, "Use of satellite technologies for power system measurements, command, and control," *Proceedings of the IEEE*, Vol. 93, Issue 5, pp. 947-955, May 2005.
- [14] L. Ri-Kun, J. Yue-Feng, L. Hui, "Optimized Design and Implementation of TCP/IP Software Based on Embedded System," *Machine Learning and Cybernetics: International Conference in Dalian*, pp. 590-594, Aug. 2006.
- [15] J.T. Dixon, K.L. Calvert, "Effective search strategies for application-independent speedup in UDP demultiplexing," *Computer Communications and Networks: International Conference In Las Vegas, NV*, pp. 468-474, Sept. 1997.
- [16] M. Alise and R.G. Roberts and D.W Repperger, "The Wave Variable Method for Multiple Degree of Freedom Teleoperation System with Time Delay", *IEEE International Conference*, pp. 2908-2913, May 2006.
- [17] R.L. Burden and J.D. Faires, "Numerical analysis", pws-kert pub. Cop., Boston, 5th edition 1993.